



RESIDENTIAL PLASTIC SEATS



70

Seats shall be No 70 as manufactured by Bemis Manufacturing Co. Seats shall be standard weight and injection molded of solid plastic. Seats shall be closed front with cover for round bowl and feature molded-in bumpers. Color-matched Top-Tite® hinges with non-corrosive top-tightening bolts and wing nuts. Color to be _____. (specify white or fixture manufacturer's color)

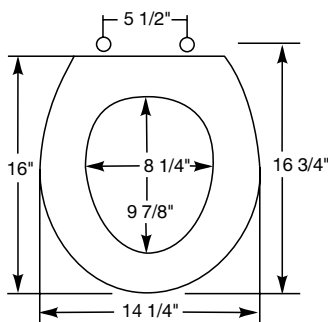

Ring thickness is 3/8"
Ring thickness including the bumper is 5/8"
Height of the seat with cover is 1-1/2"



TOP-TITE® HINGES
WITH BOLT AND WING NUT



"LOCKED-IN"
TOP-TITE® HINGE