



PLASTIC MEDIC-AID<sup>®</sup> SEATS



2L2055T

Seats shall be No. 2L2055T as manufactured by Bemis Manufacturing Co. to allow an additional 2" of height above the rim of the bowl. Seats shall contain DuraGuard<sup>®</sup>, an antimicrobial agent. Seats shall be heavy weight and injection molded of solid plastic. Seats shall be open front less cover for round bowl and feature large molded-in bumpers. Seats shall have STA-TITE<sup>®</sup>, Commercial Fastening System<sup>™</sup>, featuring external check hinges with 300 Series stainless steel posts and pintles that stop seat 11 degrees beyond vertical. Color to be white.



DuraGuard<sup>®</sup>  
ANTIMICROBIAL

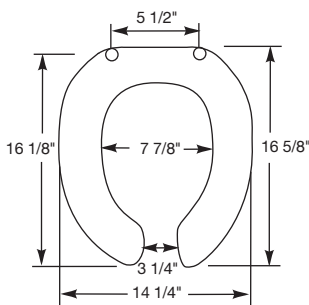

Ring thickness is 13/16"  
Ring thickness including the bumper is 2"  
Height of the seat is 3-1/4"

STA-TITE<sup>®</sup>



Assemble hinges.

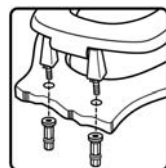

Finger-tighten fastening nuts.



Using wrench, tighten until lower portion shears off.



STA-TITE<sup>®</sup>, COMMERCIAL FASTENING SYSTEM<sup>™</sup>, ONE-PIECE INTEGRATED NUT AND WASHER



EXTERNAL CHECK HINGE WITH 300 SERIES STAINLESS STEEL BOLTS



ADDITIONAL 2" OF HEIGHT