



PLASTIC MEDIC-AID[®] SEATS



2L2050T

Seats shall be No. 2L2050T as manufactured by Bemis Manufacturing Co. to allow an additional 2" of height above the rim of the bowl. Seats shall contain DuraGuard[®], an antimicrobial agent. Seats shall be heavy weight and injection molded of solid plastic. Seats shall be open front with cover for round bowl and feature large molded-in bumpers. Seats shall have STA-TITE[®], Commercial Fastening System[™] with 300 Series stainless steel posts and pintles. Color to be white.



DuraGuard[®]
ANTIMICROBIAL

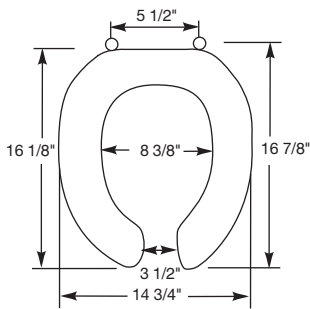

Ring thickness is 13/16"
Ring thickness including the bumper is 2-1/16"
Height of the seat with cover is 3-5/16"

STA-TITE[®]

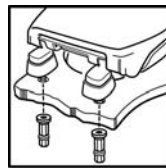

Finger-tighten fastening nuts.

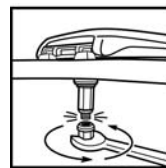

Using wrench, tighten until lower portion shears off.



STA-TITE[®], COMMERCIAL FASTENING SYSTEM[™], ONE-PIECE INTEGRATED NUT AND WASHER



EXTERNAL CHECK HINGE WITH 300 SERIES STAINLESS STEEL BOLTS



ADDITIONAL 2" OF HEIGHT