



C O M M E R C I A L P L A S T I C S E A T S



2055CT

Seats shall be No. _____ as manufactured by Bemis Manufacturing Co. Seats shall contain DuraGuard®, an antimicrobial agent. Seats shall be heavy weight and injection molded of solid plastic. Seats shall be open front less cover for round bowl and feature large molded-in bumpers. Seats shall have STA-TITE®, Commercial Fastening System™, featuring external check hinges with 300 Series stainless steel posts and pintles that stop seat 11 degrees beyond vertical.

Color to be _____.
(Specify white or fixture manufacturer's color.)

Hinges shall be 2055CT / 2055SSCT.
(Circle model based on description below.)

2055CT External check hinge stops seat 11° beyond vertical.

2055SSCT Stainless steel, self-sustaining and external check hinge holds seat in any raised position up to 11° beyond vertical.

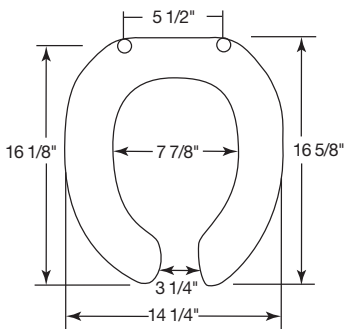

Ring thickness is 13/16"
Ring thickness including the bumper is 1"

STA-TITE®

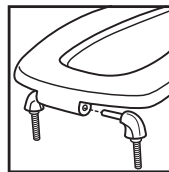

Assemble hinges.

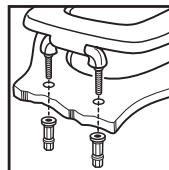

Finger-tighten fastening nuts.

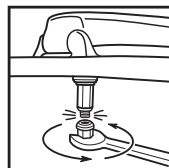

Using wrench, tighten until lower portion shears off.



STA-TITE®, COMMERCIAL FASTENING SYSTEM™, ONE-PIECE INTEGRATED NUT AND WASHER

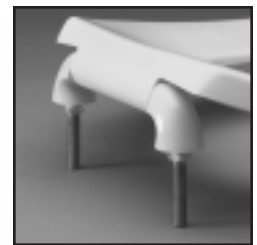

CONCEALED CHECK HINGE

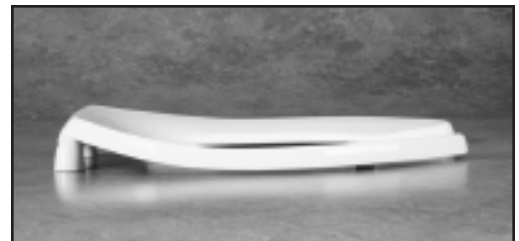

2055CT PROFILE

DuraGuard®
ANTIMICROBIAL