



C O M M E R C I A L P L A S T I C S E A T S



1950

Seats shall be No. _____ as manufactured by Bemis Manufacturing Co. Seats shall be heavy weight and injection molded of solid plastic. Seats shall be open front with cover for elongated bowl and feature large molded-in bumpers. Color-matched Top-Tite® hinges contain stainless steel pintles and non-corrosive top-tightening bolt, wing nut and no-slip washer. The “locked-in” Top-Tite® hinge design will prevent wobbling. The molded-in bumpers provide easy cleaning. Color to be white. Hinges shall be _____. (specify hinge type)



1950 Top-Tite® hinges
1950SS Self-sustaining hinges with 300 Series stainless steel pintles.

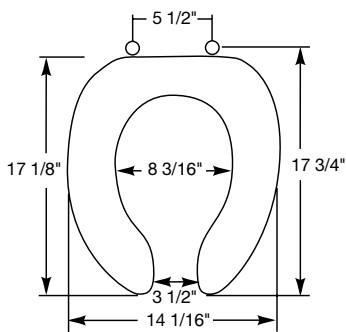

Ring thickness is 3/4"
 Ring thickness including the bumper is 1-1/16"
 Height of the seat with cover is 2-1/4"



TOP-TITE® HINGES
FEATURE NO-SLIP WASHER



“LOCKED-IN”
TOP-TITE® HINGE



300 SERIES STAINLESS
STEEL SELF-SUSTAINING
HINGE