



C O M M E R C I A L P L A S T I C S E A T S



1900

Seats shall be No. _____ as manufactured by Bemis Manufacturing Co. Seats shall be heavy weight and injection molded of solid plastic. Seats shall be closed front with cover for elongated bowl and feature large molded-in bumpers. Color-matched Top-Tite® hinges contain stainless steel pintles, non-corrosive top-tightening bolts, wing nuts and no-slip washers. The "locked-in" Top-Tite® hinge design will prevent wobbling. The molded-in bumpers provide easy cleaning. Color to be white. Hinges shall be _____. (specify hinge type)



1900 Top-Tite® hinges.
1900SS Self-sustaining hinges with 300 Series stainless steel pintles.

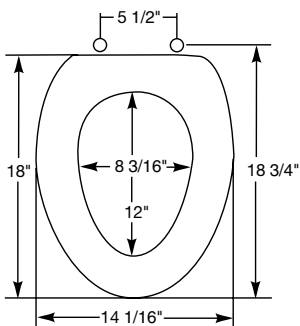

Ring thickness is 3/4"
Ring thickness including the bumper is 1-1/16"
Height of the seat with cover is 2-1/4"



TOP-TITE® HINGES
FEATURE NO-SLIP WASHER



"LOCKED-IN"
TOP-TITE® HINGE



300 SERIES STAINLESS
STEEL SELF-SUSTAINING
HINGE