



COMMERCIAL PLASTIC SEATS



1955CFR

Seats shall be No. 1955CFR as manufactured by Bemis Manufacturing Co. Seats shall contain DuraGuard®, an antimicrobial agent. Seats shall contain FirePro™, a fire retardant material to meet UL-94VO flammability rating. Seats shall be heavy weight and injection molded of solid plastic. Seats shall be open front less cover for elongated bowl and feature large molded-in bumpers. External check hinges to feature 300 Series stainless steel posts that stop seat 11 degrees beyond vertical. Uses 300 Series stainless steel hardware. Color to be white. Hinges shall be _____.

- 1955CFR Open front seat less cover/external check hinge stops seat 11° beyond vertical.
- 1955SSFR Open front seat less cover/ stainless steel, self-sustaining and external check hinge holds seat in any raised position up to 11° beyond vertical.

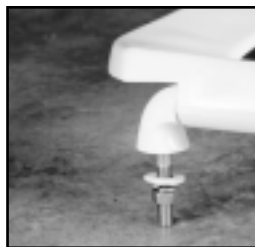
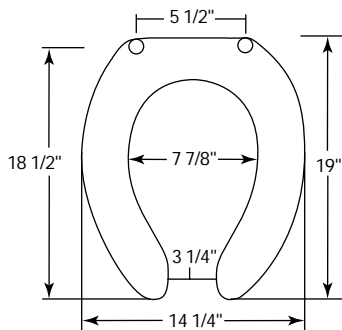

EXTERNAL CHECK HINGES WITH 300 SERIES STAINLESS STEEL POST



EXTERNAL CHECK HINGE



Ring thickness is 13/16"
Ring thickness including the bumper is 1"