



C O M M E R C I A L P L A S T I C S E A T S



1655CT

Seats shall be No. _____ as manufactured by Bemis Manufacturing Co. Seats shall be extra heavy weight and injection molded of solid plastic. Seats shall be open front less cover for elongated bowl and feature large molded-in bumpers. Seats shall have STA-TITE®, Commercial Fastening System™, featuring external check hinges with 300 Series stainless steel posts and pintles that stop seat 11 degrees beyond vertical.

Color to be _____.
(Specify white or fixture manufacturer's color.)

Hinges shall be 1655CT / 1655SSCT.
(Circle model based on description below.)

1655CT External check hinge stops seat 11° beyond vertical.
1655SSCT Stainless steel, self-sustaining and external check hinge holds seat in any raised position up to 11° beyond vertical.

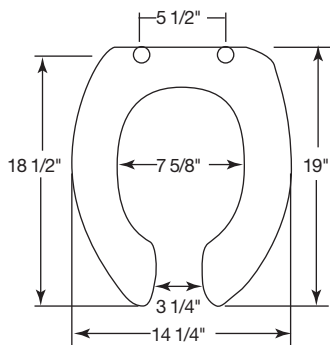

Ring thickness is 1"
Ring thickness including the bumper is 1-3/16"

STA-TITE®

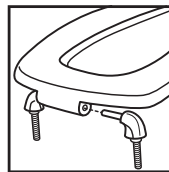

Assemble hinges.

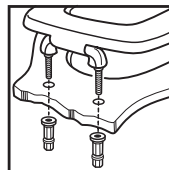

Finger-tighten fastening nuts.

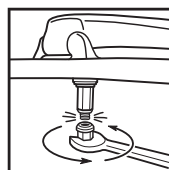

Using wrench, tighten until lower portion shears off.

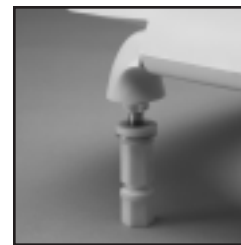

STA-TITE®, COMMERCIAL FASTENING SYSTEM™, ONE-PIECE INTEGRATED NUT AND WASHER

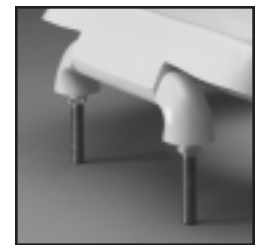

CONCEALED CHECK HINGE



CONTOURED SEAT

** ANSI Z124.5 section 5.1.2 Tests have shown that this product will support weights up to 500 pounds.** (Contact Bemis Mfg. Co., for test data)